

CAD FILE:

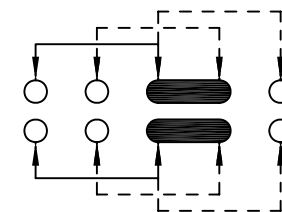

SCHEMATIC (SHORTING)

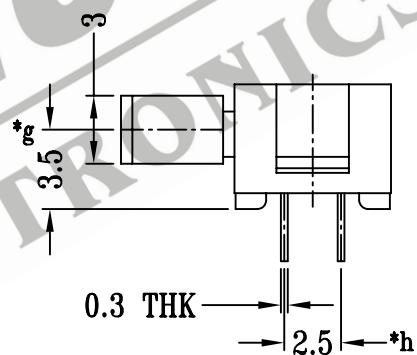
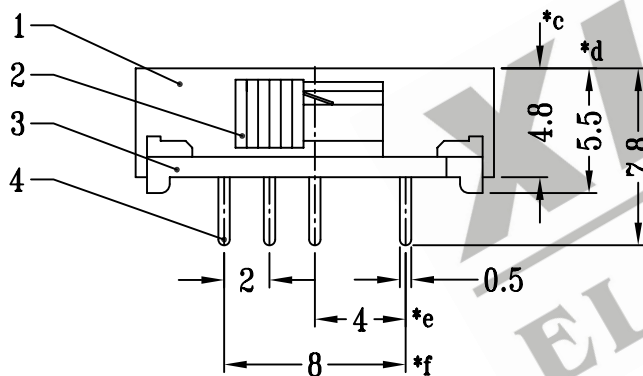
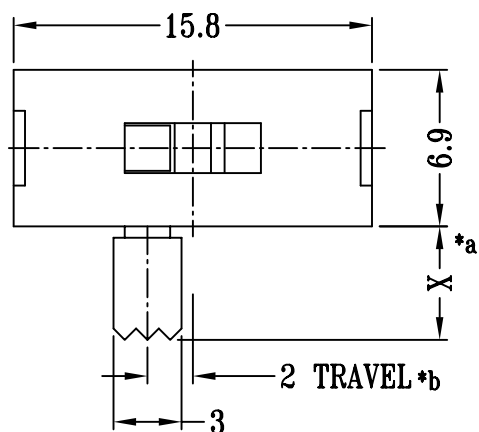
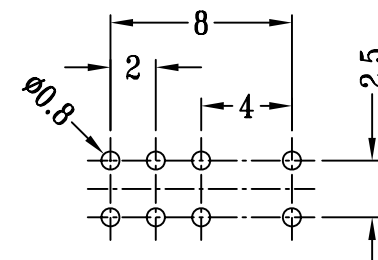

P.C.B LAYOUT

注:带"*"表示关键尺寸(8个)

					TOLERANCE UNLESS SPECIFIED		SHENZHEN XIEJIA ELECTRONICS CO.,LTD.				
					WITHIN: 1.5±0.1mm OVER : 1.5±0.2mm		ISSUE	DATE	DESCRIPTIONS		APPD.
8											
7											
6	SPRING PLATE	STAINLESS STEEL	1	NATURAL							
5	CONTACT CLIP	PBS	2	Ag CLAD							
4	TERMINAL	BRASS STRIP	8	Ag PLATED OVER Ni PLATED	TITLE : HORIZONTAL SLIDE SWITCH			UNIT : MM	DRWG NO.: XJ-DR-SK23D14-00		
3	BASE	PC	1	BLACK	MODEL: SK-23D14			SCALE: 3:1	DWN.	ZHOUYU	20004-5-31
2	KNOB	POM	1	BLACK					CHK'D	FANGYING	20004-5-31
1	HOUSING	POM	1	BLACK	ALL MATERIALS MUST BE COMPLIANT TO ROHS				APPD.	KANGXINAN	20004-5-31
NO.	PART NAME	MATERIAL	Q'TY	FINISHING							